



800-228-8861
 502-968-2211
 rental.sales@wareinc.com
 www.wareinc.com

STOCK EQUIPMENT

WARE Offers New/Used Equipment In Stock

BOILER INFORMATION

Manufacturer Victory Energy
 Year 2019
 Type Saturated Steam
 Capacity 600 HP / 20,700 PPH
 Pressure 250 PSI
 Burner Powerflame LNICM11-go-3I

CONNECTION SIZES

Main Steam 8" 300#
 Natural Gas 4" NPT
 #2 Oil 1-1/2" NPT
 Feedwater 2" 300#
 Bottom Blowdown 2" 300#
 Continuous Blowdown 1-1/2" NPT

FUEL CONSUMPTION

Natural Gas 25,150 SCFH
 #2 Oil 181.6 GPH

ELECTRICAL POWER REQUIREMENTS

480V, 3 Ph, 60 Hz

CONTROLS

Honeywell 7800 Series

EMISSIONS DATA

NOx .036# / mmBtu w/17% FGR
 SO2 .001# / mmBtu
 CO .15# / mmBtu
 PM .008# / mmBtu

BOILER OVERALL DIMENSIONS & WEIGHT

Length/Width/Height approx: 292" / 118" / 136"
 Shipping Weight ~47,000 lbs
 Operating Weight ~76,500 lbs

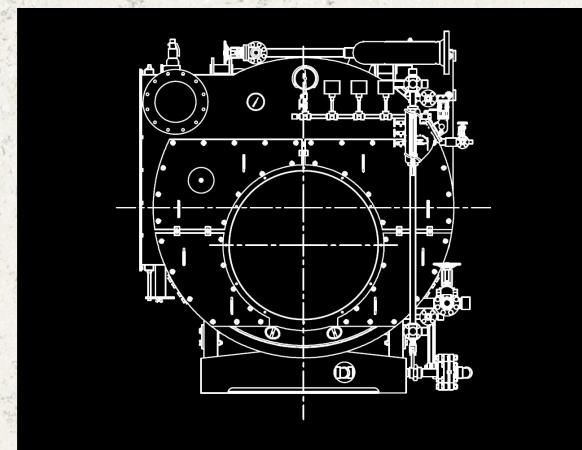

ADDITIONAL INFORMATION

SSB-42
 Model:
 F3-DB-596C-600X0-S250-SB-FGR

Firetube Boiler, 3-Pass, Dryback, 600 BHP, 250 psig with a Powerflame Low NOx Natural Gas & #2 Oil burner system. Burner has a 6:1 turndown ratio and is rated for 25.15 mmBtu gas input.

Package meets UL & CSD-1 codes.

The boiler is offered with a one (1) year parts and motors warranty (less labor) and the pressure vessel is guaranteed to pass an ASME inspection.